

OFFICE

DEALER

INSTALLATION

STOR-DECK STAIR & LANDING INSTALLATION AND DOCUMENT LIST

REV. DATE 7/16/09

<u>DWG.#</u>	<u>REV. DATE</u>	<u>PART NUMBER</u>	<u>DESCRIPTION</u>
SL009	7/16/09	INSTALLATION	TYPICAL CHANNEL PLOT PLAN
CM010	AS NOTED	INSTALLATION	STAIR & LANDING FRAMING PLAN
SL012	10/10/02	INSTALLATION	LOST OR DAMAGED GOODS
CM015	AS NOTED	INSTALLATION	PACKING LIST
SL018	10/10/02	INSTALLATION	TOUCH UP PAINT
CM020	AS NOTED	INSTALLATION	SUGGESTED STAIR & LANDING DECK PLAN(S)
CM050	AS NOTED	INSTALLATION	HARDWARE LIST
SL053	10/10/02	INSTALLATION	GENERAL ERECTION (PG 1 OF 5)
SL054	6/29/09	INSTALLATION	GENERAL ERECTION (PG 2 OF 5)
SL055	6/27/09	INSTALLATION	GENERAL ERECTION (PG 3 OF 5)
SL056	7/2/09	INSTALLATION	GENERAL ERECTION (PG 4 OF 5)
SL057	6/29/09	INSTALLATION	GENERAL ERECTION (PG 5 OF 5)
SL059	10/10/02	INSTALLATION	CHANNEL INSTALLATION DRAWING
SL065	10/10/02	INSTALLATION	QUALITY CONTROL REPORT
SL100	6/27/09	INSTALLATION	TYPICAL SIDE VIEW THROUGH PPI CHANNEL
SL110	6/27/09	INSTALLATION	TYPICAL SIDE VIEW THROUGH PPA CHANNEL
SL111	7/2/09	INSTALLATION	DECK FASTENING METHOD (PG 1 OF 2)
SL112	7/2/09	INSTALLATION	DECK FASTENING METHOD (PG 2 OF 2)
SL120	7/15/09	INSTALLATION	TYPICAL CHANNEL STAIR & LANDING
CM130	7/30/96		FAB\QC COVER SHEET
CM149	7/30/96	TP	OSHA TALL POST W/STANDARD FOOTPLATE
CM150	7/30/96	SP	OSHA SHORT POST W/STANDARD FOOTPLATE
CM151	7/30/96	TP	OSHA TALL POST W/OFFSET FOOTPLATE - CORNER
CM152	7/30/96	SP	OSHA SHORT POST W/OFFSET FOOTPLATE - CORNER
CM153	7/30/96	TP	OSHA TALL POST W/OFFSET FOOTPLATE - CENTER
CM154	7/30/96	SP	OSHA SHORT POST W/OFFSET FOOTPLATE - CENTER
CM155	7/30/96	HPO/FBW	OSHA HALF POST & FLAT BAR WASHER
CM155-A	7/30/96	HPB/FBW	BOCA HALF POST & FLAT BAR WASHER
CM156	7/30/96	TP	BOCA TALL POST W/STANDARD FOOTPLATE
CM157	7/30/96	TP	BOCA TALL POST W/OFFSET FOOTPLATE - CORNER
CM158	7/30/96	TP	BOCA TALL POST W/OFFSET FOOTPLATE - CENTER
CM160	7/30/96	CMWT 18	18" WALL TIE
CM500	7/30/96	CCA	CHANNEL TO CHANNEL
CM510	7/30/96	CCS	CHANNEL TO CHANNEL - SPECIAL
CM520	7/30/96	CCBL	CHANNEL TO CHANNEL LEFT - TYPE B
CM530	7/30/96	CCBR	CHANNEL TO CHANNEL RIGHT - TYPE B
CM540	7/30/96	PCL	POST TO CHANNEL - LEFT
CM550	7/30/96	PCR	POST TO CHANNEL - RIGHT
CM560	7/30/96	PCBL	POST TO CHANNEL - LEFT - TYPE B
CM570	7/30/96	PCBR	POST TO CHANNEL - RIGHT - TYPE B
CM580	7/30/96	PPA	POST TO POST

STOR-DECK STAIR & LANDING INSTALLATION AND DOCUMENT LIST

REV. DATE 7/16/09

<u>DWG.#</u>	<u>REV. DATE</u>	<u>PART NUMBER</u>	<u>DESCRIPTION</u>
CM589	7/30/96	PP0I	POST TO POST W/0 INTERMEDIATES
CM590	7/30/96	PP1I	POST TO POST W/1 INTERMEDIATE
CM600	7/30/96	PP2I	POST TO POST W/2 INTERMEDIATES
CM610	7/30/96	PP3I	POST TO POST W/3 INTERMEDIATES
CM620	7/30/96	PP4I	POST TO POST W/4 INTERMEDIATES
CM630	7/30/96	PP5I	POST TO POST W/5 INTERMEDIATES
CM633	7/30/96	PP6I	POST TO POST W/6 INTERMEDIATES
CM635	7/30/96	PP7I	POST TO POST W/7 INTERMEDIATES
CM637	8/23/96	PP8I	POST TO POST W/8 INTERMEDIATES
CM640	7/30/96	DG&GB	OSHA DROP GATE & GATE BRACKET
CM645	7/30/96	DGB&GBB	BOCA DROP GATE & GATE BRACKET
CM660	7/30/96	SGL	OSHA SWING GATE - LEFT
CM665	7/30/96	SGLB	BOCA SWING GATE - LEFT
CM670	7/30/96	SGR	OSHA SWING GATE - RIGHT
CM671	7/30/96	SGRB	BOCA SWING GATE - RIGHT
CM673	7/30/96	DSG	OSHA DOUBLE SWING GATE
CM675	7/30/96	DSGB	BOCA DOUBLE SWING GATE
CM677	7/30/96	SLIDE	OSHA SLIDING GATE
CM677B	7/30/96	SLIDEB	BOCA SLIDING GATE
CM678	8/20/96	DMNDPALL	DIAMOND PLATE PALLET PADS (W/6" LIP)
CM679	8/20/96	DMNDTRDS	STANDARD DIAMOND PLATE TREAD PANS
CM680	7/30/96	SBPPI & SBPPA	DIAGONAL SWAY BRACES
CM750	7/30/96	HR & TG	OSHA HAND RAIL & TOE GUARD
CM752	7/30/96	HRB & TGB	BOCA HAND RAIL & TOE GUARD
CM755	7/30/96	TGS	SPECIAL TOE GUARD/FASCIA
CM770thruCM799SB-D	6/29/09	STAIR&ENDPLT	STAIR & STAIR ENDPLATE
CM785A	8/20/96	VERTLAD	VERTICAL LADDER ATTACHING IN THE PPA DIRECTION
CM785I	8/20/96	VERTLAD	VERTICAL LADDER ATTACHING IN THE PPI DIRECTION
CM810	6/29/09	SHIPLAD	LEVEL 1 SHIPS LADDER-STANDARD RAIL
CM810-A	8/27/08	SHIPLAD	LEVEL 2 SHIPS LADDER-STANDARD RAIL
CM811	2/18/09	SHIPLAD PLATE	LEVEL 1 SHIPS LADDER END PLATE
CM811-A	1/31/01	SHIPLAD PLATE	LEVEL 2 SHIPS LADDER END PLATE
CM812	6/29/09	SHIPLAD	LEVEL 1 SHIPS LADDER-HATCH ACCESS RAIL
CM812-A	8/27/08	SHIPLAD	LEVEL 2 SHIPS LADDER-HATCH ACCESS RAIL
CM878thruCM981-G	6/29/09	STAIR&ENDPLT	STAIR & STAIR ENDPLATE

STEEL CHANNEL MEZZANINE TYPICAL PLOT PLAN

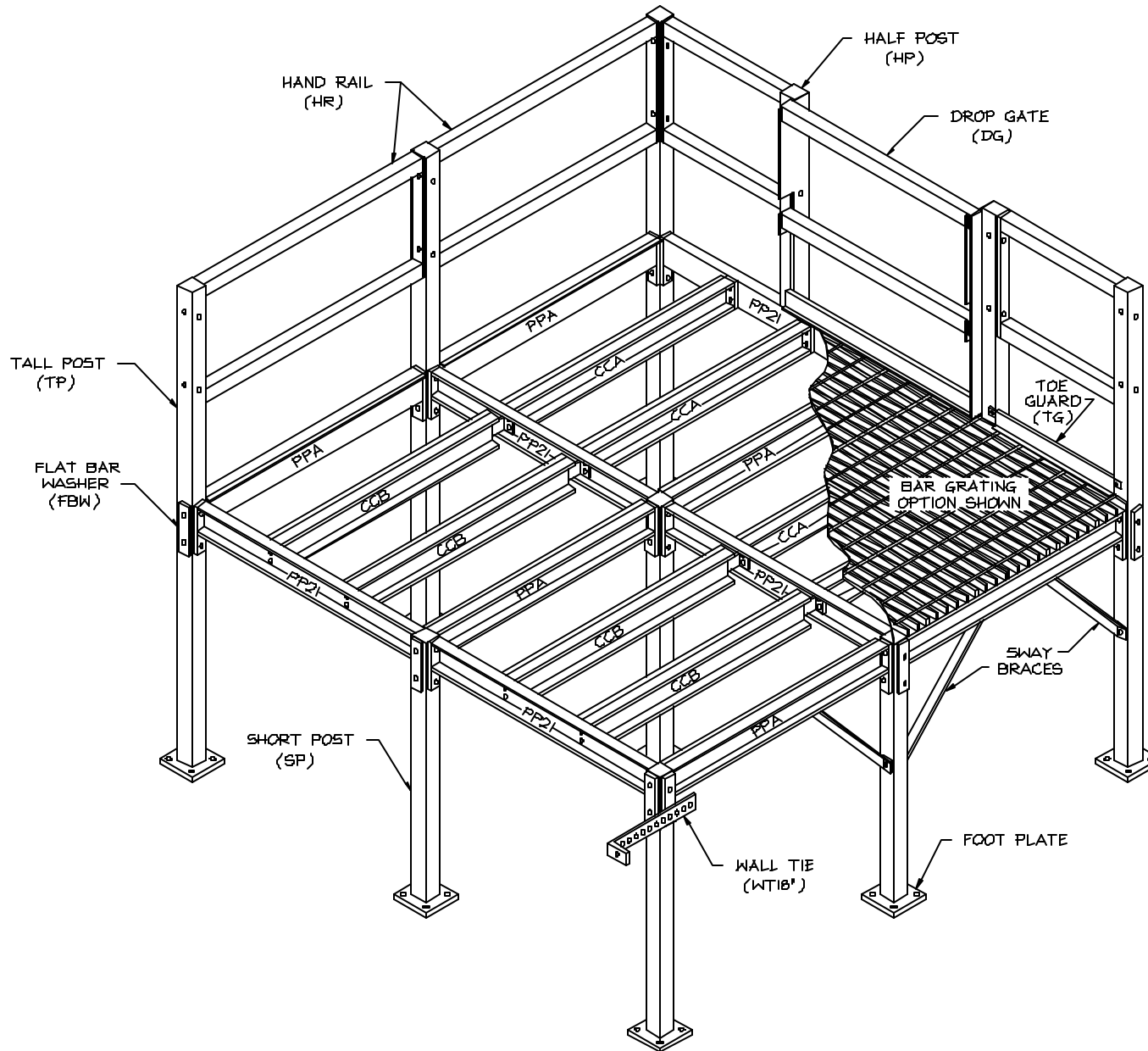

LOST OR DAMAGED GOODS

**You should thoroughly inspect this shipment
at the time it is received!**

This material was carefully counted, packaged and properly loaded for shipment when accepted by the carrier.

In the event of any loss or damage, the delivery receipt **MUST BE SIGNED AND NOTED AS SUCH**. You must notify your freight agent at once and request him/her to make an inspection report. This is absolutely necessary. If not done, the transportation company will not entertain any claim for loss or damage.

After an inspection report and claim have been submitted to the carrier, you must retain the material for possible carrier pick-up, prior to the payment of a claim.

This material was shipped FOB Shipping Point. Contrary to popular belief, FOB (Free On Board) does not determine who pays the freight. FOB is the point where the title of the goods passes from seller to buyer. The carrier now acts as an agent for the buyer.

In accordance with common law, the responsibility of the seller ceases at the time the carrier picks up the freight.

**WE ARE WILLING TO ASSIST YOU IN EVERY POSSIBLE MANNER IN COLLECTING
CLAIMS FOR LOSS OR DAMAGE IN TRANSIT, BUT THIS DOES NOT MAKE US
RESPONSIBLE FOR COLLECTION OF CLAIMS OR REPLACEMENT OF THE MATERIAL.**

TOUCH UP PAINT

Color # 1: _____

Color # 2: _____

Size of can: _____

Size of can: _____

Number of cans: _____

Number of cans: _____

Color # 3: _____

Color # 4: _____

Size of can: _____

Size of can: _____

Number of cans: _____

Number of cans: _____

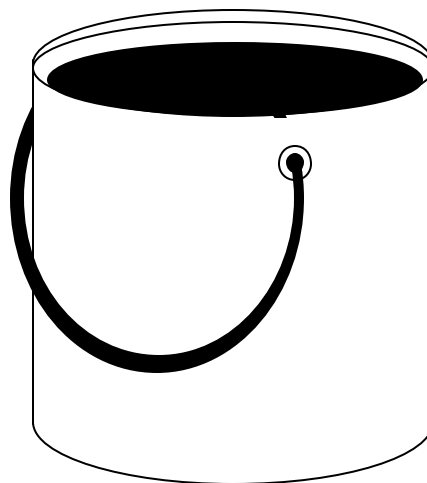

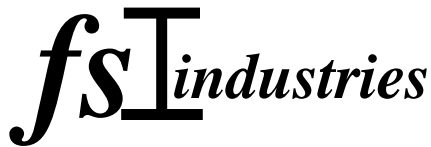

STEEL STAIR & LANDING INSTALLATION INSTRUCTIONS

GENERAL ERECTION REQUIREMENTS

SL053

Page 1 of 5

FS Industries' products are precision engineered and manufactured. For this reason, the following erection requirements shall be followed:

Drawing Deviations - Any deviation from component and assembly drawings shall be approved, in writing and in advance, by FS Industries.

Material Substitution - Material substitutions shall not be made without advance written approval of FS Industries.

Welding - * All field welding shall be performed in accordance with all applicable provisions of the American Welding Society* (AWS) Structural Welding Code.

Welding Processes - Field weld joints specified on FSI drawings are prequalified to the AWS code, but limited to manual shielded metal arc, submerged arc, gas metal arc (except short circuiting transfer), and flux - cored arc weld procedures.

Columns - Columns shall be installed within one quarter (1/4) inch of vertical. Column Base Plates (footplates) shall be grouted or shimmed to insure uniform bearing pressure.

Anchorage - Unless otherwise specified on a Material Specifications Sheet or on the installation drawing, positive attachments of all vertical columns, stairs, and other load carrying elements at floor level shall be accomplished using an approved wedge type anchor bolt. Installation shall be in accordance with manufacturer's specifications at the locations indicated on the installation drawing(s).

Bolting - Bolted connections shall be made, insuring contact between members, and adequately torqued.

Decking - Decking fasteners shall be installed and torqued to insure contact between joined components.

Foundations - Footings, foundations, and slabs shall be designed to distribute and support column loads specified on FSI drawings.

Seismic Loading - Unless otherwise specified on drawings or in writing by FS Industries, FS Products are designed for seismic loading.

General - * Assembly and erection shall be in accordance with applicable provisions of the American Institute of Steel Construction (AISC), Manual of Steel Construction, and any local State and Federal Building Codes, Specifications, Laws or Acts having jurisdiction in the location of the FS Industries Products installation unless FS Industries Product Drawings or FS Industries written documents specify more stringent requirements.

* Revision for documents is to be that in effect at the time of installation.

Procedures - All methods, operations, and erection procedures shall be performed in accordance with the provisions of the Occupational Safety and Health Administration (OSHA).

STEEL STAIR & LANDING INSTALLATION INSTRUCTIONS

SL054
Page 2 of 5

**NOTE: Before beginning installation, read and follow
General Erection Requirements document, SL053.**

Before starting installation all material should be checked. A piece count should be done to determine that you have received all the components shipped.

1. Establish a starting point (preferably a corner). Select proper post from framing plan. Key on the framing plan will tell you whether a tall post is required (if hand rail is to connect to it) or short post. (See sheet SL009)
2. Next, select the channel needed to connect to either side of corner post. Each channel is clearly marked on framing plan and can then be looked up in the component sheets provided. Channels themselves are labeled with tags on the end plates.
3. Confirm that the channel corresponds to the component sheets paying particular attention to the location of holes in the end plates. If the holes in the end plates are 2" down from the top, the upper set of holes in the column are used. Holes 3" down use the lower holes. (See sheet SL110)
4. The first channel can now be raised into position and fastened to the post using 5/8"-11 x 5 1/2" bolts (C40), nuts (C44) and lockwashers (C46) provided. (See sheet SL110)
5. Be sure to use 2" x 3/8" flat bar washers provided on the outboard side of post. (See sheet SL009)
6. Post at the opposite end of channel should now be selected and installed following the same procedure. When bolting channel to post, bolts should be installed through channel, then through post to facilitate installation of next channel if applicable. (See figure 1 of sheet SL059)
7. The next channel to be installed should be 90 degrees from the first running off the corner post. (See figure 2 of sheet SL059)
8. Install post at the opposite end of the channel. If orientation of the bolt holes is correct, the channels intersecting at the corner post will be at the same level on the top. (See figure 3 of sheet SL059)

STEEL STAIR & LANDING INSTALLATION INSTRUCTIONS

SL055
Page 3 of 5

9. After installing second channel, you should have a PPI and a PPA installed. At this point, the next channel to be installed should be a PPI. By erecting this channel, a U-shaped structure is created. (See figure 3 of sheet SL059)
10. CCA's or CCB's can now be installed working from previously installed PPA toward the open side of structure. Always install bolt through PPI so that nut and lockwasher are on the open side of the channel. Doing this will allow fastening adjacent channel without removing fasteners. Do not fully tighten bolts at this time. Repetition of this procedure can be followed to erect all remaining bays. (See figure 4 of sheet SL059)
11. After all framing structure has been erected, be sure mezzanine is straight and square. Measuring corner to corner to corner of the bays at the point where the channels meet the post is a good check for square.
12. At this point the bolts can be tightened. Starting in a corner, be sure channels are perpendicular to the floor. It may be necessary to rotate channels slightly before tightening.
13. After framing is tight, the next step is to plumb all the posts and fasten securely to the floor. This step is critical and care should be taken to insure that posts are straight and plumb. Depending on the condition of the floor, it may be necessary to shim under posts to make mezzanine level.
14. Determine the location of the stairway(s) from framing plan. (Refer to sheet SL120) Establish the left and right hand stair stringers (smooth side of stringer face each other). Raise a stringer into position and fasten it to the mounting channel using 5/8"-11 x 2" bolts (C42), nuts (C44) and lockwashers (C46) provided, or to a post, sharing the bolts used to attach the channel to the opposite side of the post. Follow the same procedure for the opposite stringer. When the stringers are properly installed they should extend above mezzanine framing the thickness of the deck being used. Start at the bottom and bolt the treads into the stringers using 3/8"-16 x 1 1/2" bolts (C24), nuts (C26), lockwashers (C28) and flatwashers (C30) provided. DO NOT tighten the bolts until all the treads have been installed.
15. If column sway braces are provided, they can be installed at this time and where possible, wall ties should be used to insure the stability of the mezzanine. (See sheets CM160 and CM680)

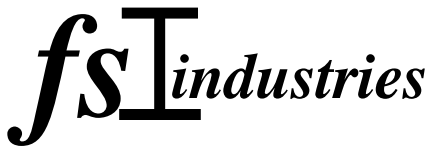

STEEL STAIR & LANDING INSTALLATION INSTRUCTIONS

SL056
Page 4 of 5

16. Use applicable decking instructions to install deck from types listed below:

DECKING PROCEDURES

a. 1 1/2" Corrugated B-deck & Plywood or B-deck & Diamond Plate/Smooth Plate

Consult B-deck plan provided to establish starting point of deck. All B-deck panels lap one another side to side and length to length. B-deck is fastened to channels using 12-24 x 1 1/4" TEK #5 screws (C10) provided. End of B-deck panels should have a screw (C10) in each corrugation touching the channel and they should be installed in alternate corrugations where they meet the channels along the interior length of the B-deck panel.

(See sheet SL111) **NOTE:** If screws are used to attach B-deck to supports, a 12-24 x 1 1/4" TEK #5 is advised. If deck is welded then Arc Puddle Welds are generally the most efficient and economical method of attaching steel deck to structural supports. Either E60XX or E70XX welding rods are recommended and the amperage must be adjusted to individual jobsite requirements: the American Welding Society Specifications for Welding Sheet Steel in Structures should be followed. Plywood in this case, will be screwed down from the top through the B-deck using 1 5/8" HI-LO screws (C15) provided. Plywood should be laid out to insure that the end of a sheet of plywood does not fall in the trough of the B-deck below. A quantity of fifteen (15) screws per 4' x 8' sheet of plywood are provided. Diamond or smooth plate in this case, will be riveted down from the top through the B-deck using #66 domed head rivets (C20) provided. Diamond/Smooth plate should be laid out to insure that the end of a sheet of plate does not fall in the trough of the B-deck below. It will be necessary to drill a 13/64" diameter hole in the diamond/smooth plate and B-deck to accept the rivets. A quantity of fifteen (15) rivets per 4' x 8' sheet of plate steel will be provided. Some field trimming may be required around the posts and landing. (See sheet SL111)

b. Bar Grating

Consult deck plan provided to establish starting point of deck. Install bar grating planks over steel channel framework per this deck plan. Either tack weld grating planks in place or use TEK screws & W-clips provided to bolt bar grating in place. If bolting grating, use 1/4"-14 x 1/2" TEK screws (C12) provided to screw down through W-clips (C14) into angle welded to channels. 24" wide panels should have (2) TEK screws & W-clips per deck support channel they touch and 36" wide panels should have (3) per channel they touch. Some field trimming may be required around the posts and landing. (See sheet SL112)

c. 1/8" Diamond Plate/Smooth Plate

Consult deck plan provided to establish starting point of deck. Diamond plate will be riveted down from the top using #66 domed head rivets (C20) provided. Fasten diamond plate to structural angle on back of intermediate channels. It will be necessary to drill a 13/64" diameter hole in the diamond plate to accept the rivets. A quantity of (15) rivets per sheet of diamond plate will be provided. Some field trimming may be required around the posts and landing (See sheet SL112)

d. Special Deck

If the deck material provided is not one of the above, a separate set of deck installation instructions is attached.



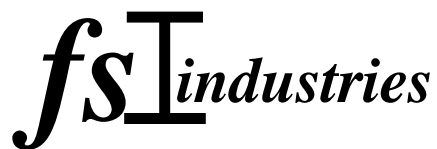

STEEL STAIR & LANDING INSTALLATION INSTRUCTIONS

SL057
Page 5 of 5

17. After all deck has been installed per the deck plan, the fascia trim angle should be installed (if provided) on the exposed perimeter sections of the mezzanine using TEK screws (C10) as shown on sheets SL100 & SL110. TEK screws are provided for fastening on approximately 2' centers. Fascia angle is provided in 10' lengths and may require field cutting. Note: fascia angle is provided with B-deck & top deck only.
18. Handrails are identified on deck plan and are fastened between posts, using 5/8" x 5 1/2" long bolts (C40) nuts (C44) and lockwashers (C46) provided. (See sheets SL100 & SL110)
19. Toe guards should be installed on the inboard side of mezzanine posts, with 1" flange on the bottom, facing in. Toe guards are then TEK screwed (C10) to the posts through the tabs on each end. Intermediate screws can be installed through 1" flange into decking as needed. (See sheets SL009, SL100 and SL110)
20. Drop gates are denoted on print as "DG". Drop gate brackets are installed on posts where indicated toward the inboard side of mezzanine. This enables the user to merely lift gate out of one bracket and slide the gate to the side without actually removing the entire gate. Drop gates are mounted on inboard side of mezzanine posts. (See sheets SL009 and CM640) Note: if drop gate falls in the corner of the mezzanine, it may be necessary to shim the gate bracket.
21. Final checks! After assembly is completed, verify that all bolts have been tightened, posts are plumb and that mezzanine is rigid and free of sway or lateral movement. Remove all piece mark tags that remain on any components.

**STEEL STAIR & LANDING
INSTALLATION INSTRUCTIONS**

SL059

Figure 1

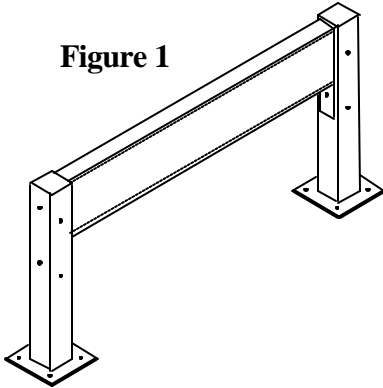

Figure 2

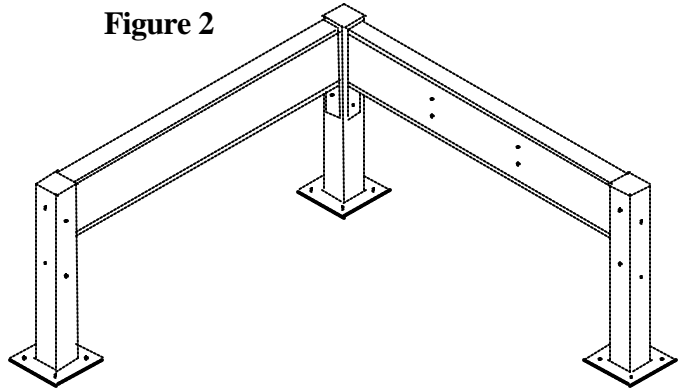

Figure 3

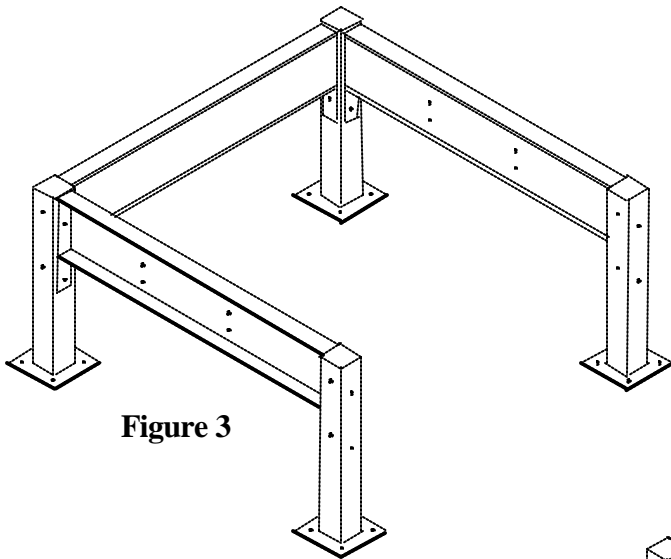
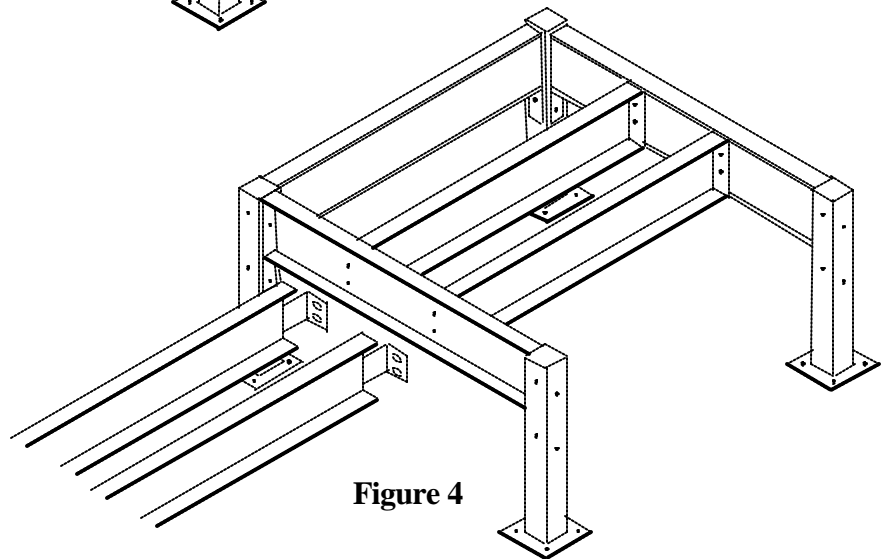

Figure 4



STOR-DECK STAIR & LANDING INSTALLATION QUALITY CONTROL REPORT

Job No: _____ Name/Customer: _____

1. Condition mezzanine as received: _____

(Explain): _____

2. Installation package: (comment) _____

Blue print _____

Component sheets _____

Labeling of steel components _____

Representative drawing _____

Written instructions _____

Deck plan (Did you follow it?) _____

3. Hardware supplied: _____

4. Steel fabrication: _____

Holes drilled properly _____

Steel Channel/beam cut length _____

Handrail/Pallet gate _____

Stairway _____

5. Describe any field modification you may have had to make: _____

6. In your opinion - anything and everything you could suggest to help FS Industries

improve on our mezzanines (ease of installation, fabrication, design) _____

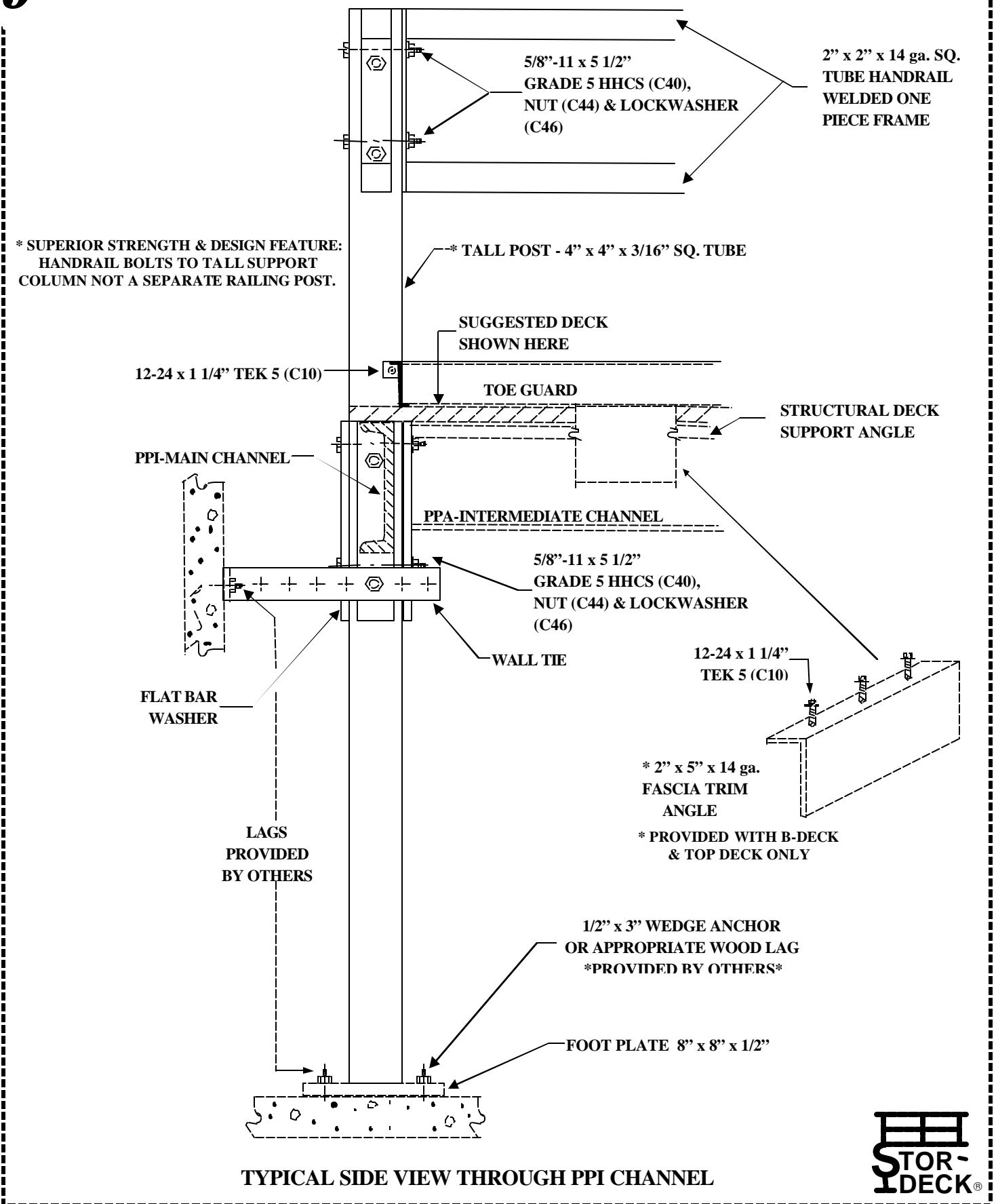

* SUPERIOR STRENGTH & DESIGN FEATURE:
HANDRAIL BOLTS TO TALL SUPPORT
COLUMN NOT A SEPARATE RAILING POST.

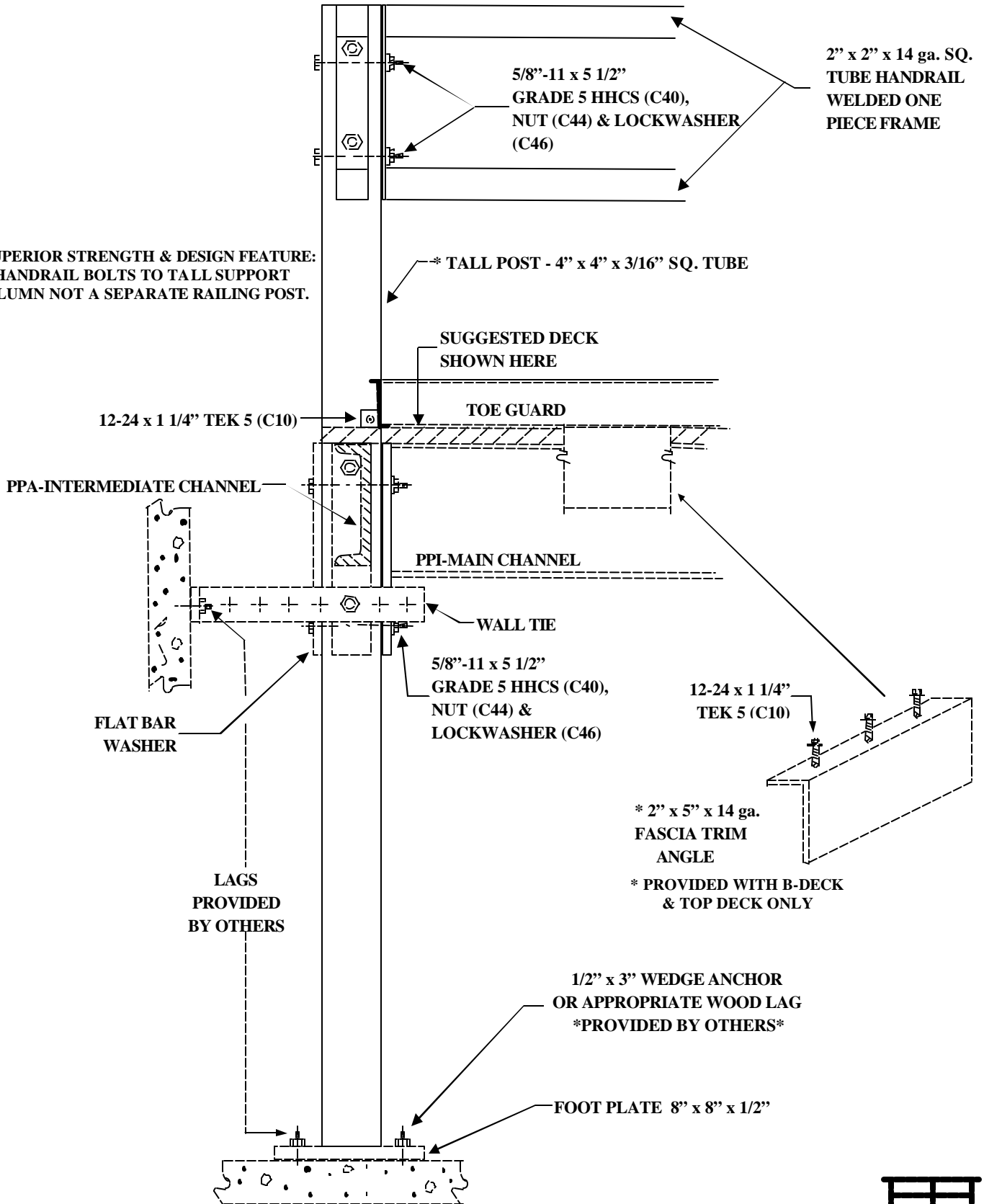

TYPICAL SIDE VIEW THROUGH PPA CHANNEL



3/4" PLYWOOD OVER 1 1/2" CORRUGATED B-DECK

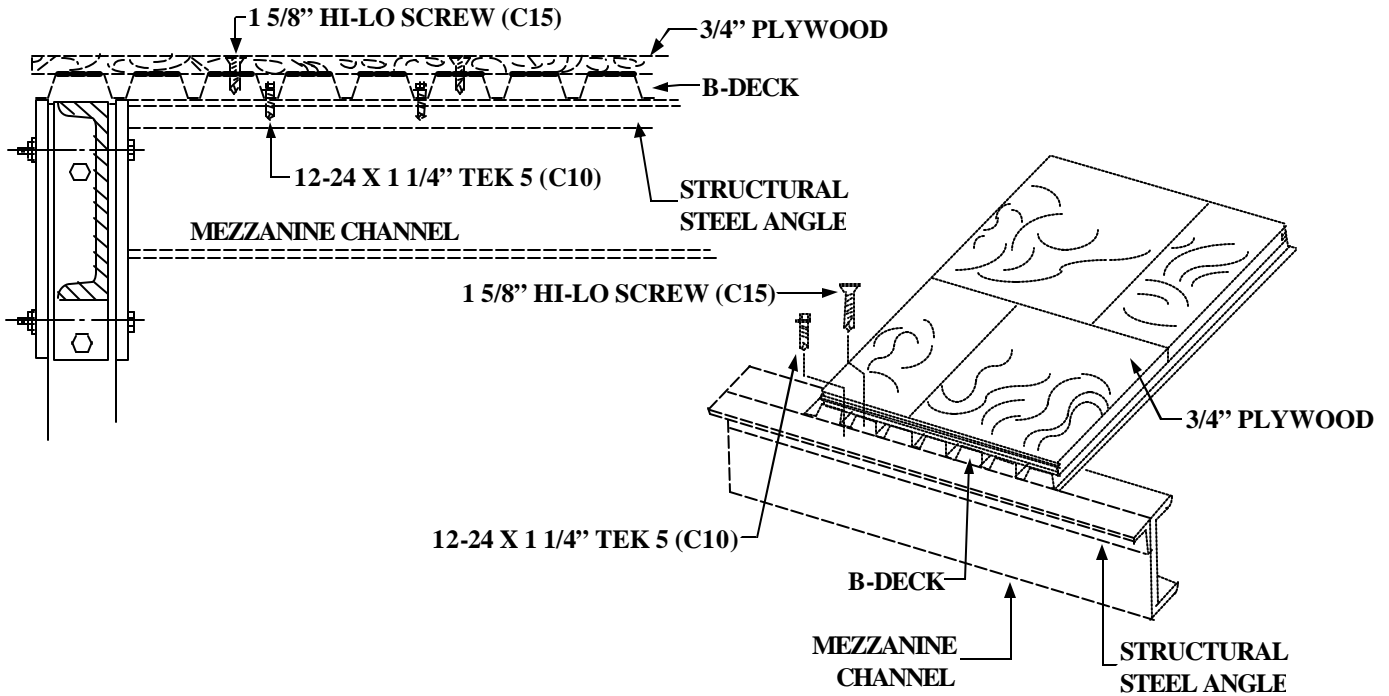

DIAMOND/SMOOTH PLATE OVER 1 1/2" CORRUGATED B-DECK

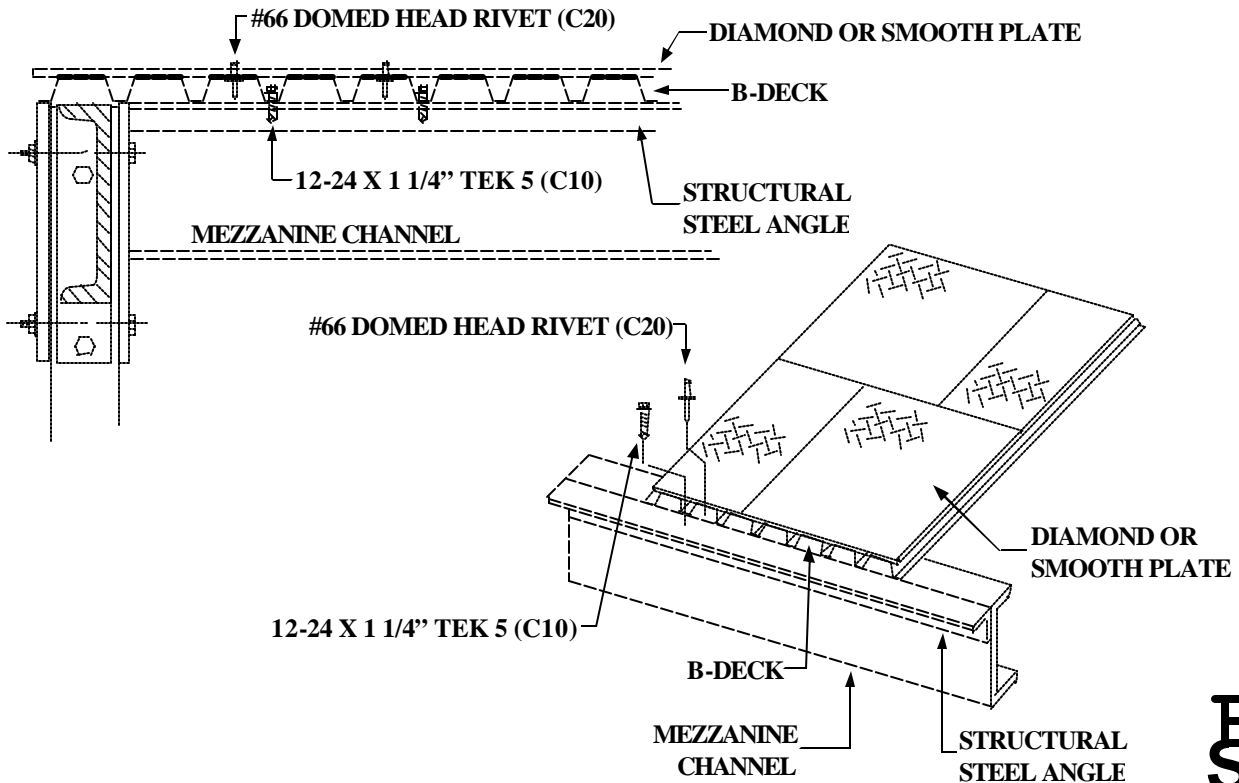

REFER TO PAGE SL056



BAR GRATING

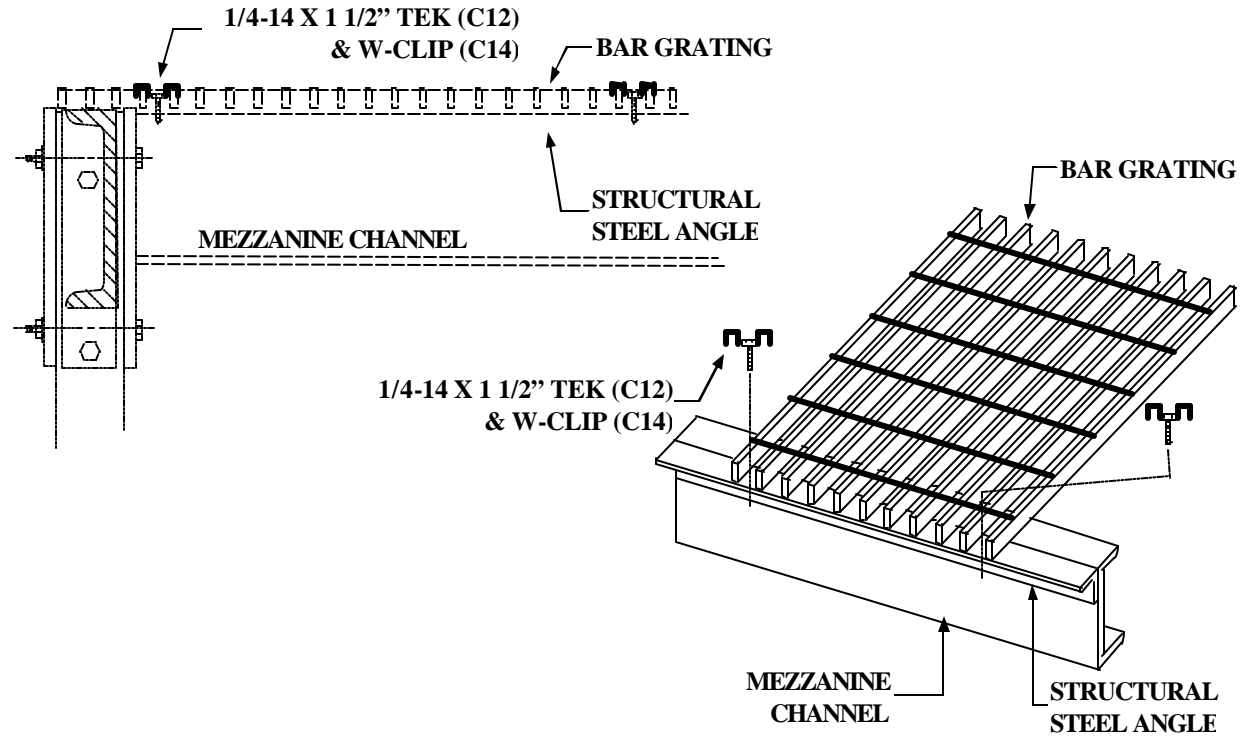

1/8" DIAMOND PLATE/SMOOTH PLATE

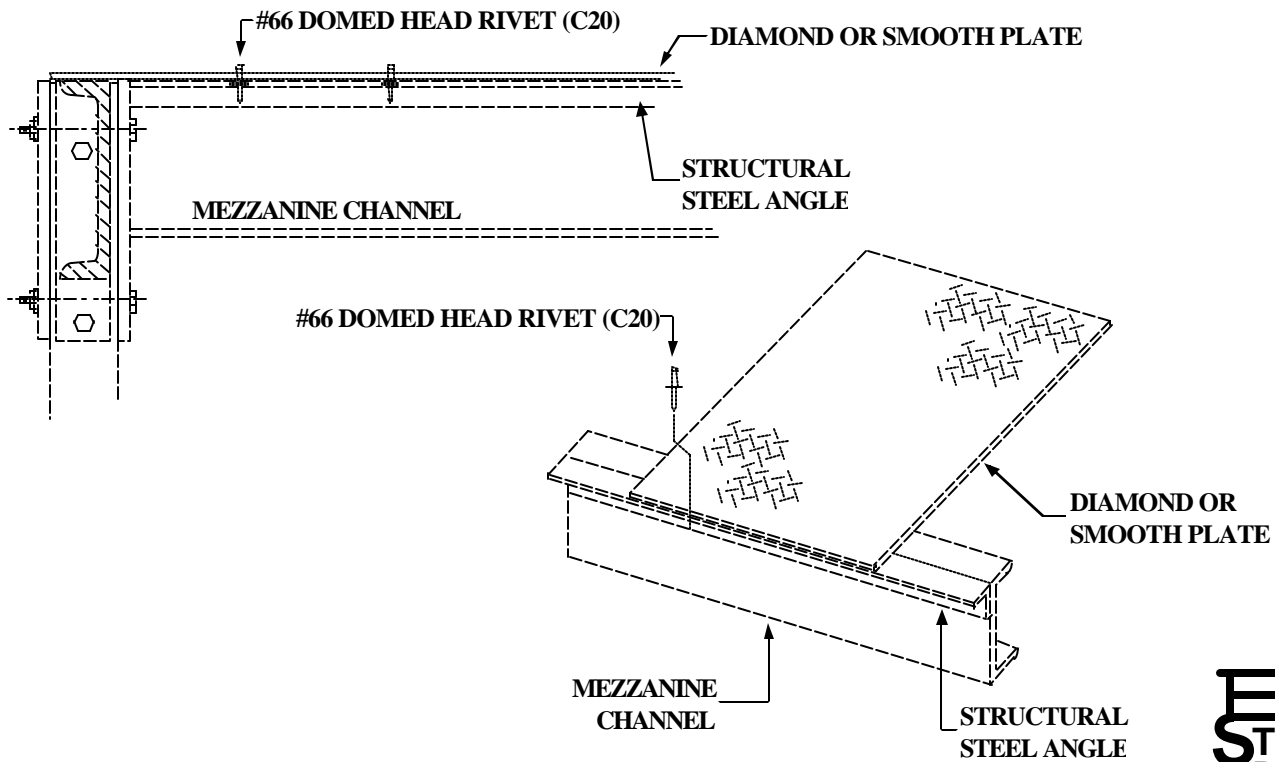

REFER TO PAGE SL056



ResinDek® Installation Instructions

1. ResinDek® should be installed over corrugated metal B-decking or an existing mezzanine floor surface.

ResinDek is not intended for exterior applications.

RESINDEK PRODUCTS NOT INSTALLED IN ACCORDANCE WITH THE FOLLOWING INSTRUCTIONS WILL VOID ALL WARRANTIES.

2. ResinDek panels must be kept dry in transit, storage, during and after installation. Panels should be stored flat in a level position.

3. ResinDek Installation Process:

- Begin installation by setting a true line with a laser or transit less than 48" from one edge of mezzanine.
- Leave a 3/8" gap/space on outer edges of ResinDek, and leave 1/8" gap/space between ResinDek panels. Trim the last row of panels to allow for the 3/8" gap/space on outer edges of ResinDek perimeter.
- Attached to each unit of ResinDek is a package of 3 panel spacers. Insert metal spacers (2 along one long edge, 1 along a short edge) between all adjacent panels. **FAILURE TO USE METAL PANEL SPACERS MAY ALLOW FLOOR TO BUCKLE AND WILL VOID ALL WARRANTIES.**
- Attach panels to corrugated metal B-deck or other approved subflooring using a minimum of 20 fasteners per 4' x 8' sheet. (See **Figure A**)
For best results, use ResinDek screws furnished by FS Industries. Fasteners should be located a minimum of 1" from tongue and groove edges and from square edges. Remove panel spacers and insert between next panels.
- Be sure that panels are installed with the correct face on top. When correctly laid, the arrow on the square edge of the panel should point up and panels should have a space of a panel spacer's width around the perimeter of each ResinDek panel, and about 1/4" on the underside of the tongue and groove. The gap/space will always be larger on the underside.
- Stagger panels so that joints break on different ribs wherever possible.

4. ResinDek Pallet Load Recommendations (pallet jack and load)

- Do not exceed 2,000 lbs. live & dead load on ResinDek® LD.
- Do not exceed 3,000 lbs. live & dead load on ResinDek® MD.
- Do not exceed 4,500 lbs. live & dead load on ResinDek® HD.

Substructures must be capable of supporting the above loads. Failure of substructure may result in local failure of ResinDek. Use 20 gauge or heavier corrugated metal B-deck for substructure. 18 gauge is recommended for 2,500 lb. loads or greater.

5. ResinDek Cleaning & Maintenance

- If ResinDek with Clear Diamond Seal®, Gray Diamond Seal® or ESD finish has been installed, the surface is quite cleanable and durable. Unfinished ResinDek will clean up similar to other unfinished wood products.
- ResinDek with Clear Diamond Seal®, Gray Diamond Seal® or ESD finish can be easily cleaned using a damp mop and/or ordinary cleaning solvents. Do not use methylene chloride or paint thinners on ResinDek.
- Prolonged and extensive soaking, hosing down, or wetting of all ResinDek products must be avoided.



- ResinDek can be installed with the long direction parallel or perpendicular to the corrugate metal B-deck. All panel joints should break on ribs. 6" wide x 20 gauge minimum steel shims must be used when ResinDek breaks on a valley. (See **Figure B**)

- Fasteners must be long enough to penetrate both the ResinDek and the subfloor. Secure each panel with a minimum of four fasteners before installing the next panel. Use only screw guns with a nose clutch to countersink screw heads. **DRIVE FASTENERS SO THAT THE COUNTERSUNK HEAD IS JUST BELOW THE PANEL SURFACE.**

- ResinDek can be trimmed to size with ordinary power saws. Use carbide tipped blades for best results.
- 3/8" perimeter gaps/space can be hidden with toe strips or kick plates.

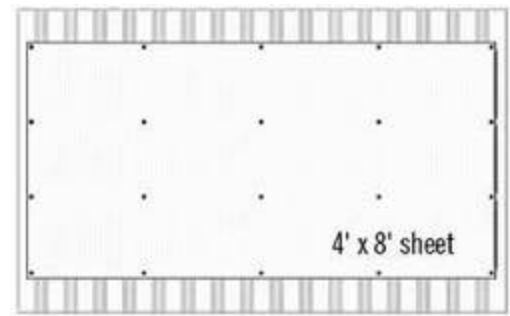

Figure A Fastener Pattern

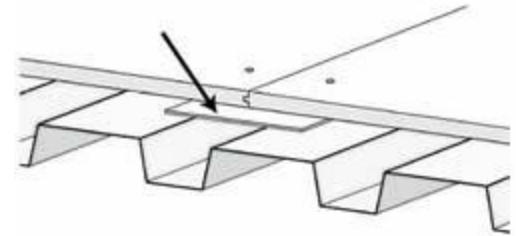
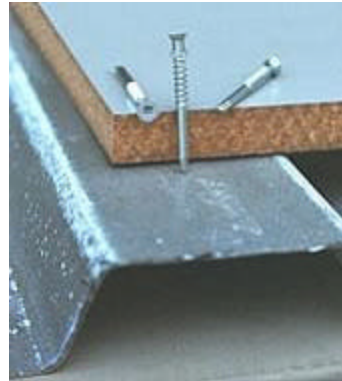
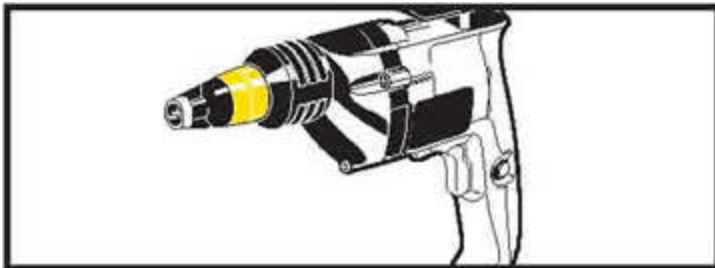

Figure B When ResinDek breaks on a valley use 6" wide 20 Ga. min. steel shims. Avoid using wood blocks, which may cause panel joints to become uneven.



WARNING: UNDER CONDITIONS OF EXTREME HUMIDITY, RESINDEK® MAY BE PRONE TO LINEAR EXPANSION.

WARNING: Common installation mistakes that can void your 7-year warranty



Must use screw driver/gun with operable clutch for consistent screw depth setting. For best results, use stand-up screw gun.



Do not use screw driver/gun with no clutch or a broken clutch.

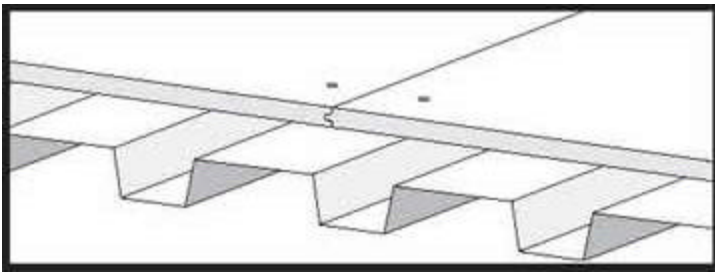

Panels must meet on high points (ribs) of corrugated B-Decking.



Do not place panel edges on top of corrugated B-Decking low points (valley).



Approved screws must be placed just below the panel surface.



Do not place approved screws too high or too low in the panels.

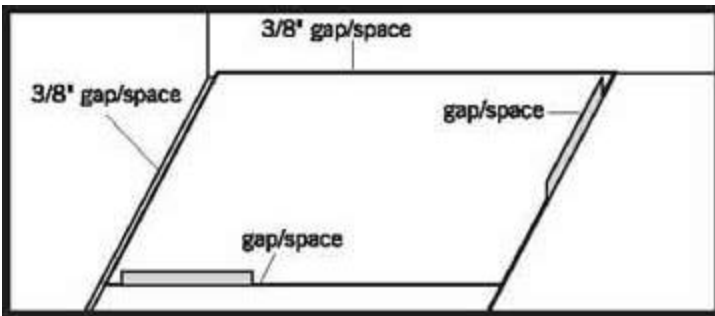

Use pacers between panels for correct spacing. 3/8" space/gap on outer edges (perimeter).

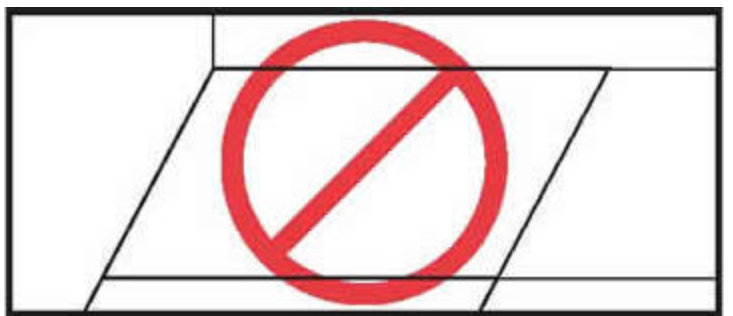

Do not install panels without 3/8" gap/space on outer edges of panel and gap/space between panels.

FAILURE TO INSTALL RESINDEK AS INSTRUCTED WILL VOID ALL WARRANTIES

